

Intelligent

DIGITAL SIGNAGE



FP Series

Fine Pitch LED Panel

Especially designed for super high-resolution Display 4K

www.intelligentsignage.cy

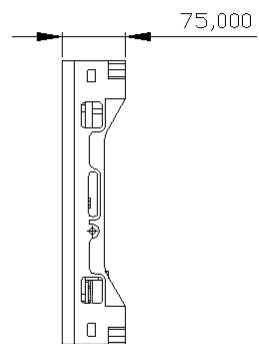
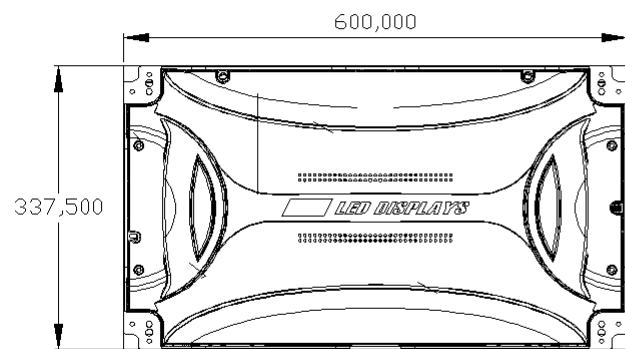

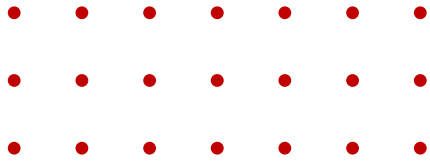

Wall mounted installation

LED module & panel modular design

100% full front maintenance

Drain hole is designed at the bottom of the panel to prevent ponding

High standard of Waterproofing

Can be immersed in the specified water pressure for a long time

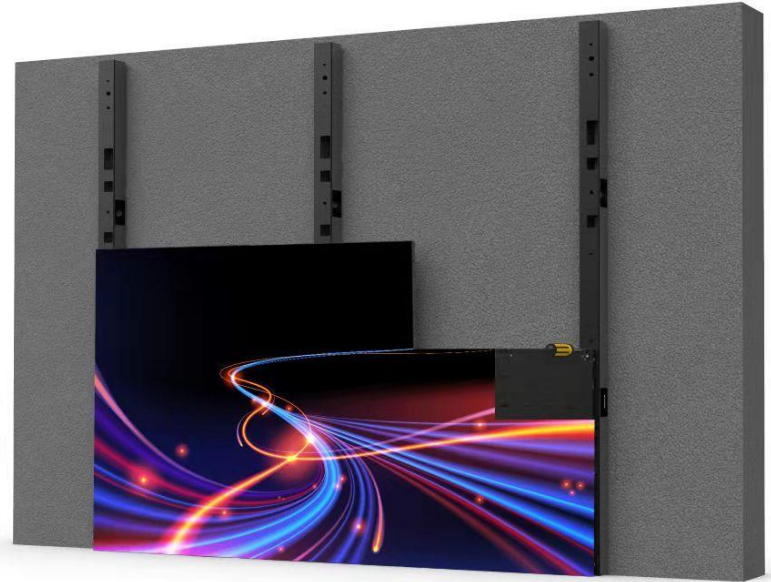

LED module & panel modular design

100% full front maintenance



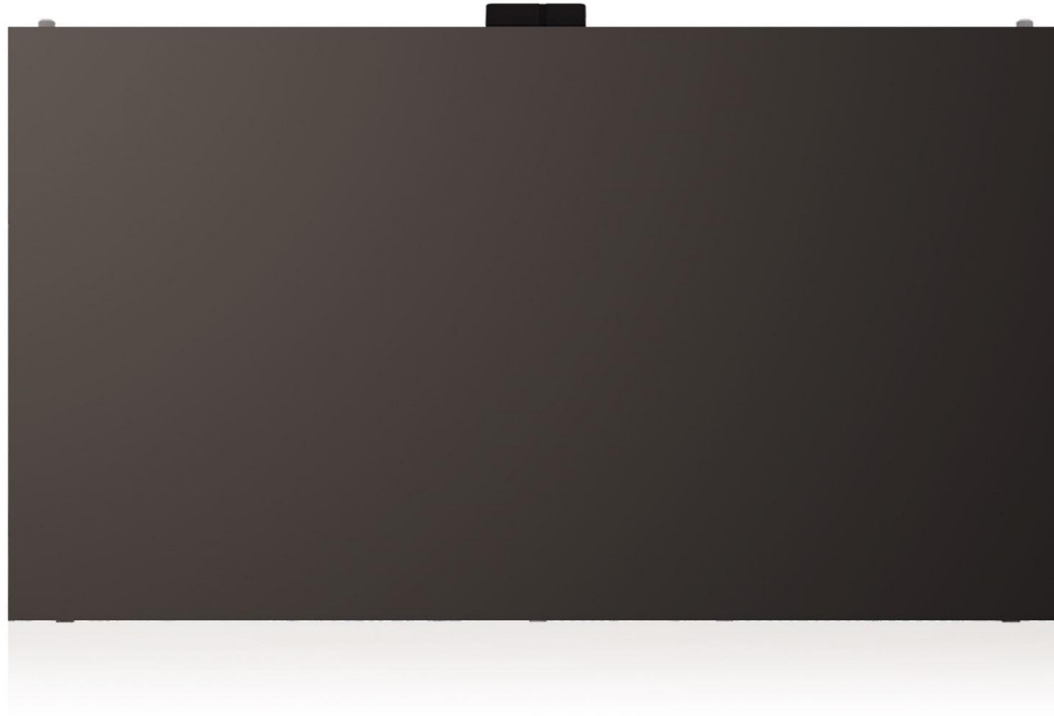

16:9 Aspect Ratio Optimized for FHD/UHD Content

Each unit case uses a 16:9 aspect ratio, the same most commonly used in displays for FHD and UHD content. This allows you to enjoy existing content without additional editing.

Full HD, 4k, 16:9

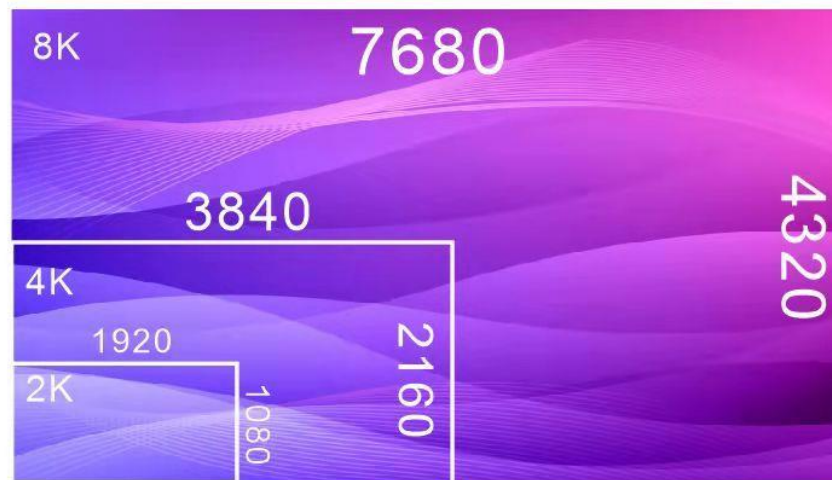
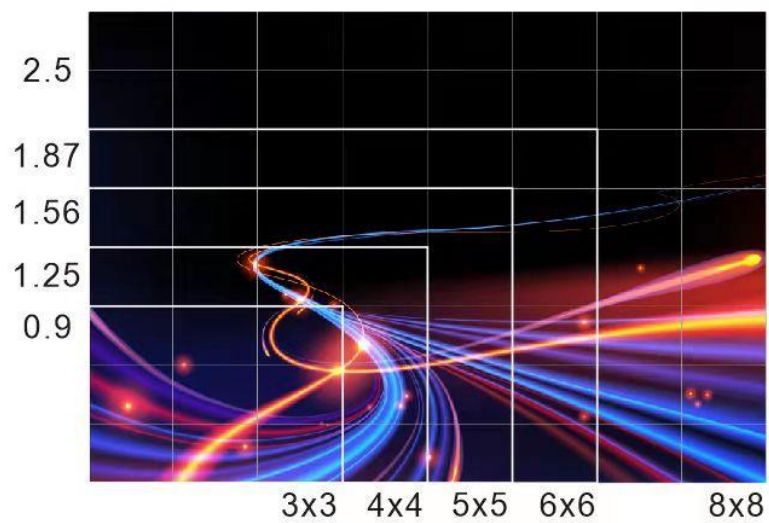

Color Accuracy

DOIT VISION rigorous quality standards also make the LED screens reproduce accurate colors, vividly displaying the original colors without distortion.

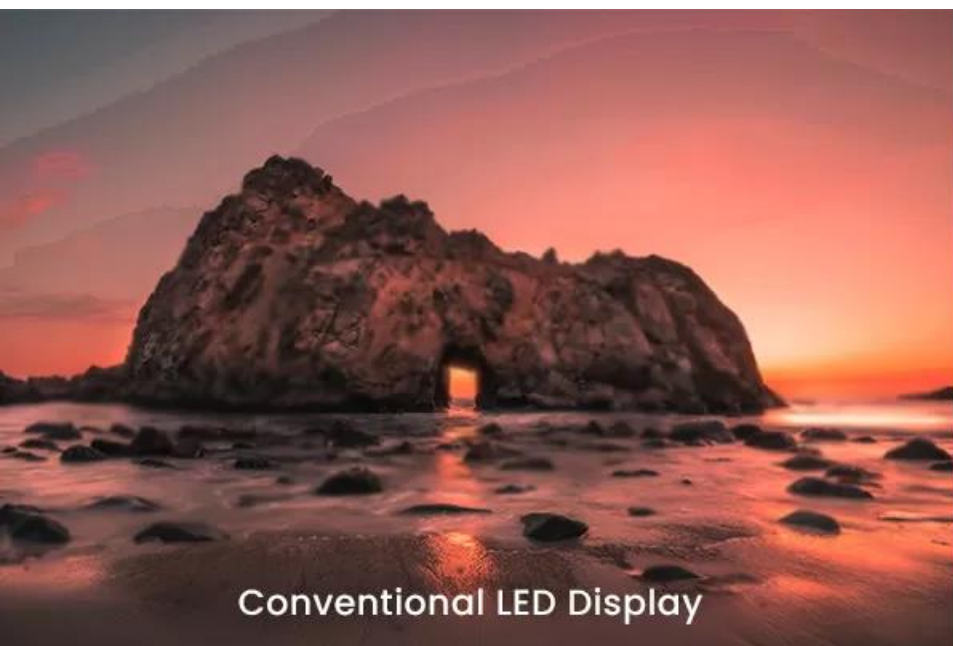



Uniform Picture Quality

Every step from production is strictly managed, while factory calibration ensures consistent quality between the LED units. The display provides seamless content with 97% brightness uniformity

The low-brightness and high-gray images are delicate and lifelike; ultra-wide viewing angle, under a variety of different angles, can show high-quality display effects

F





Control center



Monitor center

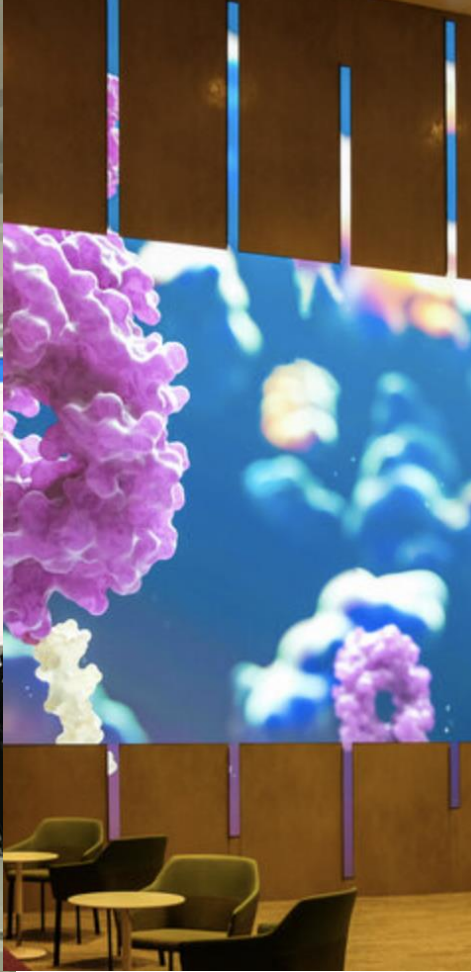

Show room



Conference room



DOIT VISION Service

Customer' value is our top priority



Free inquiry with solutions

We will quote for any inquiry within 24 hours with quotations & specifications



Free drawing

Free drawing of structure, signal & power cable connection, customized solutions if needed



7/24 online technical support

Sales technical supports are ready anytime within warranty

Contacts



Address.

10 Aigeos Street, 1st Floor, Office Suite 1
Nicosia 1035, Cyprus



Tel.

Tel: +357 22 030 030
Fax: +357 22 030 031



Email.

info@intelligentsignage.cy